

**CENTURION®**

**770 LB CAPACITY,  
STEEL UTILITY GARDEN  
WAGON CART, 48 INCH**



Note: All the safety instructions must be read and understood before attempting to operate this appliance. Failure to comply with these instructions may result in personal injury.

Save these instructions for future reference!

## **TOOLS REQUIRED:**

Flat Head Screwdriver  
Two Medium Adjustable Wrenches

**Note: Do not completely tighten screws until the assembly is complete.  
For easier assembly, we recommend two people assemble this product.**

## **PARTS ENCLOSED:**

<b>Part Number</b>	<b>Description</b>	<b>Quantity</b>
#1	Bed	1
#2	Side Panel	2
#3	Front Panel	1
#4	Back Panel	1
#5	Wheels	4
#6	Rear Axle Support	1
#7	Left Rear Axle Brace	1
#8	Right Rear Axle Brace	1
#9	Front Axle Support	1
#10	Center Front Axle Brace	1
#11	Yoke	1
#12	Steering Link Connector	1
#13	Handle Coupler	1
#14	Pull Handle	1
#15	Liner	1
#16	Quick Release Pins	8
#17	Cotter pin.	1
#18	Lock Handles(pre-attached)	4
#19	Washers	19
#20	Lock Nuts	19
#21	Large Lock Nuts	4

<b>Part Number</b>	<b>Description</b>	<b>Quantity</b>
#22	M8 x 60 Pull Handle Bolt	1
#23	M8 x 15 Steering Bolts	13
#24	M8 x 25 Steering Bolt	1
#25	Washer	4
#26	Large Yoke Washer	1
#27	Tractor Pull Bolt	1
#28	Small Quick Release Pin	1

### **CAUTION:**

*Do Not load the Garden Cart with more than 700 lbs. Do not allow children to use the cart unsupervised. This cart is not a toy! Always distribute payload evenly over the surface of the bed. Lower fencelrails when loading items onto the cart. Do not inflate tires more than 32 psi*

### **ASSEMBLY DIRECTIONS:**

Carefully remove all parts from the box and place on a smooth flat surface

#### **BACK WHEEL ASSEMBLY:**

Parts needed:

- #5 Wheels
- #6 Rear Axle Support
- #7 Left Rear Axle Brace
- #8 Right Rear Axle Brace
- #21 Large lock Nuts
- #25 Washer

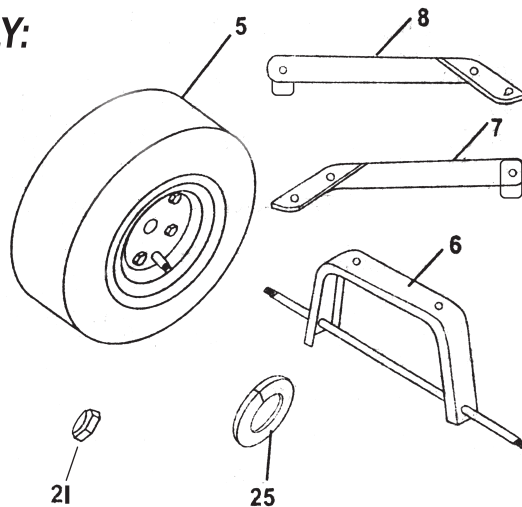

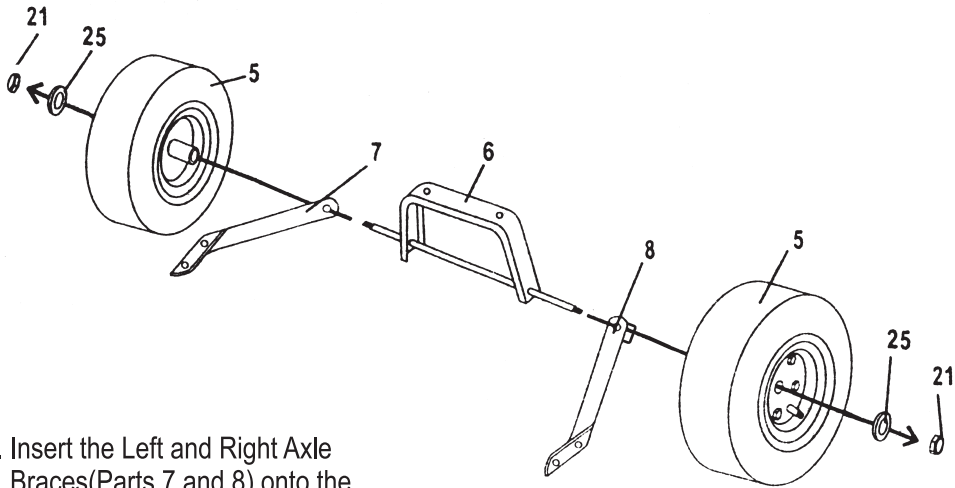

1. Insert the Left and Right Axle Braces(Parts 7 and 8) onto the extended threaded poles on the Rear Axle Support(Part 6).
2. Slide Wheels(Part 5) onto the extended threaded ends of the Rear Axle Support(Part 6).
3. Secure Wheels first with Washer(Part 25) and Large lock Nut(Part 21). Tighten large lock Nut clockwise until wheels are secure.

## **FRONT WHEEL ASSEMBLY:**

### **Parts needed:**

- #5 Wheels
- #9 Front Axle Support
- #10 Center Front Axle Brace
- #11 Yoke
- #12 Steering Link Connector
- #17 Cotter Pin
- #21 Large Lock Nut
- #23 M8 x 15 Steering Bolt
- #24 M8 x 25 Steering Bolt
- #19 Washer
- #20 Lock Nuts
- #25 Washer
- #26 Large Yoke Washer

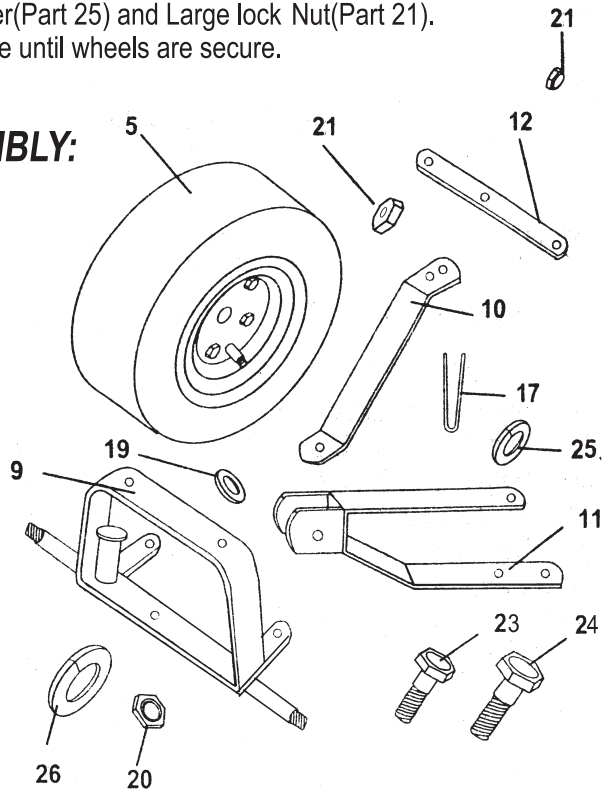



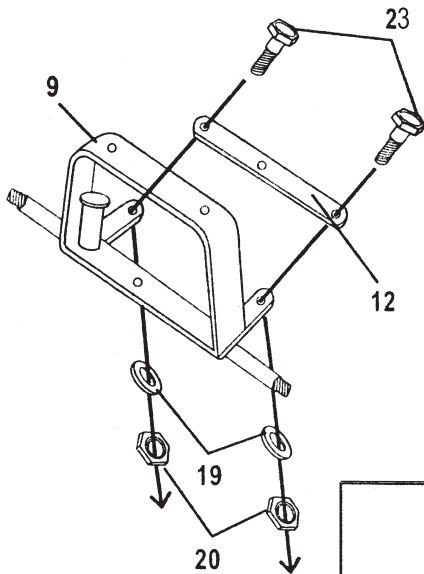

1. Attach the Steering Link Connector(Part 12) to the Front Axle Support(Part 9) by threading two M8 x 15 Bolts (Part 23) through the top of the Link connector (Part 12) and into the Axle Support(Part 9). Secure at the bottom with Washer(Part 19) and then Lock Nut(Part 20). Tighten clockwise until secure.

2. Join the Yoke(Part 11) and the Center Front Axle Brace(Part 10) to the Front Axle Support(Part 9) by first threading one M8 x 25 Bolt(Part 24) through the hole in the Center Front Axle Brace(Part 10), then into the second hole in the Yoke(Part 11) and through the hole in the bottom of the Front Axle Support(Part 9). From the bottom, insert Washer(Part 19) and secure with Lock Nut(Part 20). Tighten clockwise until secure.
3. Secure the Yoke (Part 11) to the Steering Link Connector(Part 12) by threading one M8 x 15 Bolt(Part 23) through the first hole in the Yoke(Part 11) then into the Link Connector(Part 12). Secure With Washer(Part 19) and Lock Nut(Part 20). Tighten clockwise until secure.
4. Attach the top of the Yoke(Part 11) to the appendage located on the under side(top) of the Front Axle Support(Part 9) by first inserting Large Yoke Washer(Part 26) and then inserting Cotter Pin(Part 17) into the hole in the middle of the appendage.  
NOTE: Use a flat Head Screwdriver to separate

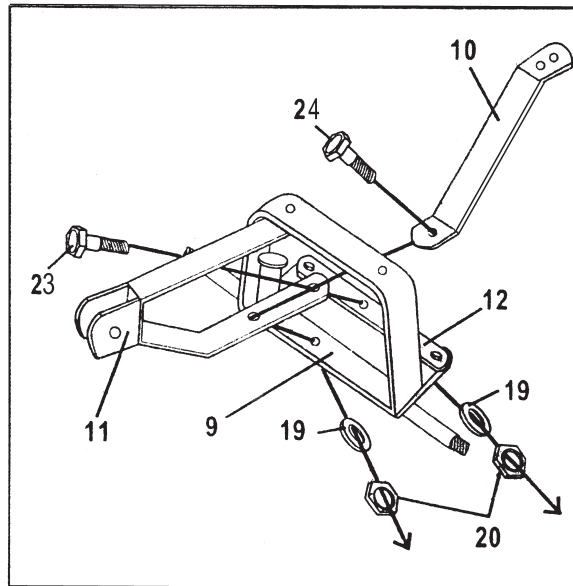

4. CONTINUED..and bend the end of the Cotter Pin outwards to lock it into place.

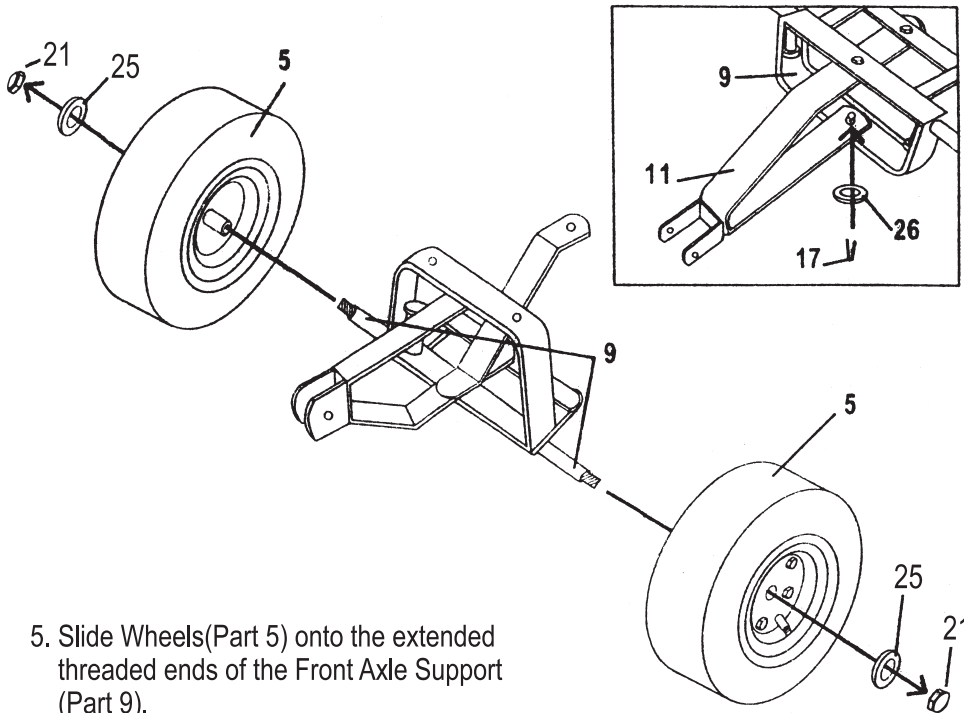

5. Slide Wheels (Part 5) onto the extended threaded ends of the Front Axle Support (Part 9).

6. Secure Wheels first with Washer (Part 25), and large lock Nut (Part 21). Tighten Large Lock Nut clockwise until wheels are secure.

## **BED ASSEMBLY:**

Parts needed:

- #1 Bed
  - #23 M8 x 15 Steering Bolts
  - #20 Lock Nuts
  - #19 Washers
  - #13 Handle Coupler
  - #14 Pull Handle
  - #15 Tractor Pull Adapter
  - #22 M8 x 60 Pull Handle Bolt
  - #27 Tractor Pull Bolt
  - #28 Small Quick Release Pin
- Front Wheel Assembly    Back Wheel Assembly

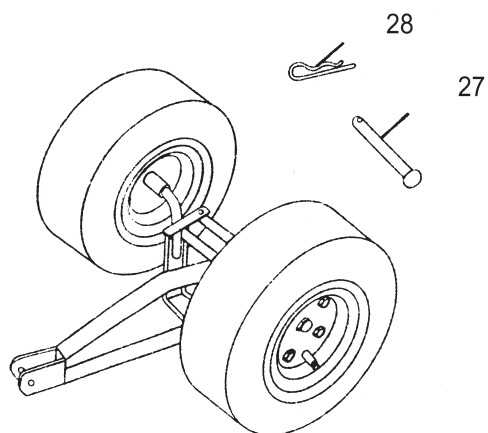

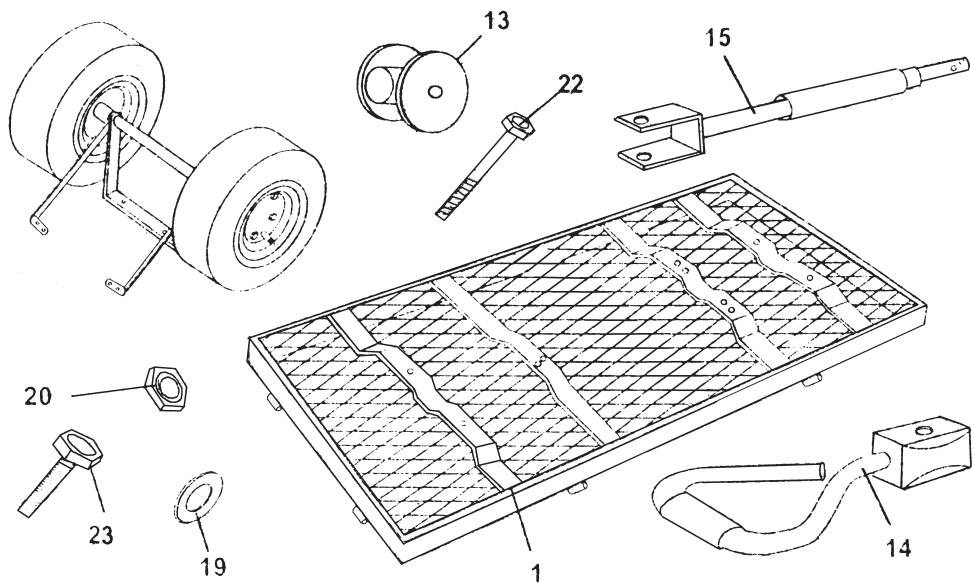

1. With the Bed(Part 1) turned upside down, attach the Back wheel assembly to the Bed by inserting six M8 x 15 Steering Bolts(Part 23) from under the bar first through the holes located on the metal support bars on the under side of the Bed then into the holes located on both the Left and Right Rear Axle Brace( Parts 7 and 8) and also the Rear Axle Support (Part 6). Next insert Washers (Parts 19) onto the Bolts then secure with Lock Nuts(Parts 20). Tighten Lock Nuts clockwise until secure.

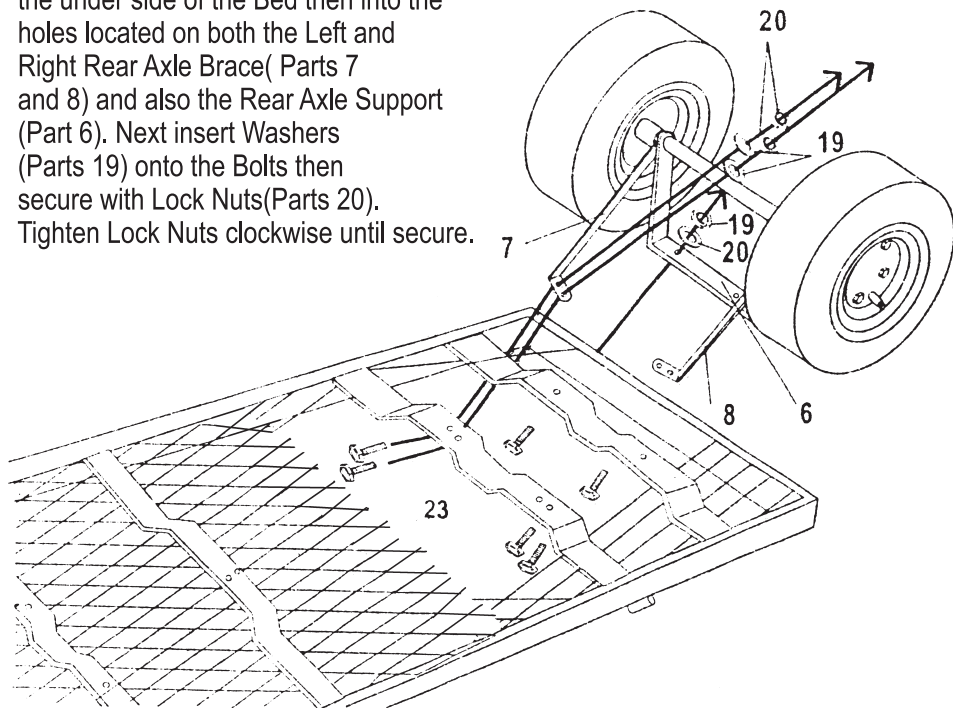

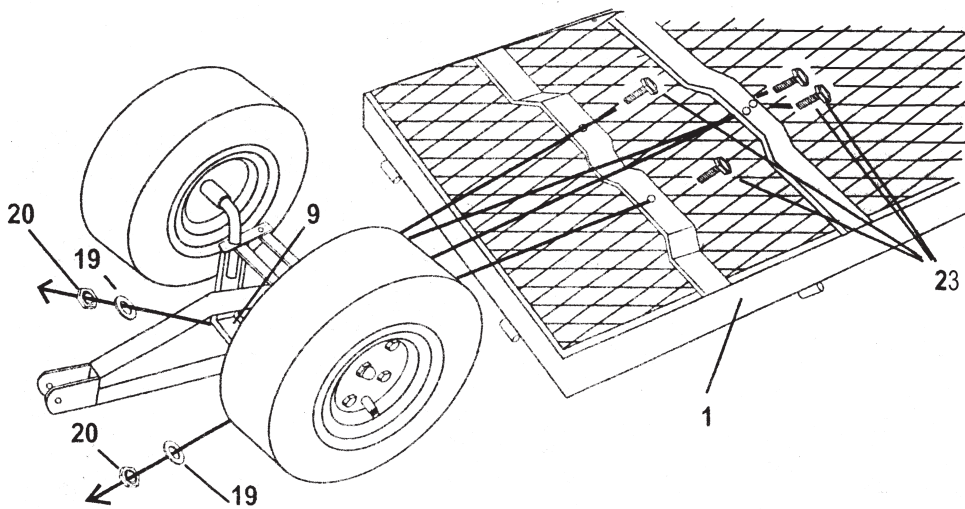

2. Join the Front Wheel Assembly to the Bed(Part 1) by inserting four more M8 x 15 Steering Bolts(Parts 23) first from under the bar through the holes in the metal support bars then into the holes in both the Front Axle Support(Part 9) and the Center Front Axle Brace(Part 10). Insert Washers(Part 19) onto the Bolts then secure with Lock Nuts(Part 20).
3. Attach either the Pull Handle(Part 14) or the Tractor Pull Adapter(Part 15) to the Yoke(Part 11) depending on which you would prefer to use.

A. Tractor Pull- Attach the Handle Coupler(Part 13) to the end of the Tractor Pull Adapter(Part 15) by simply inserting the end of the Adapter(Part 15) into the pole hole of the Coupler(Part 13). Be sure to align holes on the inside of the Adapter(Part 15) and the outside of the Coupler(Part 13). Join to the end of the Yoke(Part 11) by aligning holes and then inserting M8 x 60 Pull Handle Bolt(Part 22) into first the Yoke(Part 11), the Coupler(Part 13), then out the other side of the Yoke(Part 11). Secure with Washer(Part 19) and Lock Nut(Part 20).

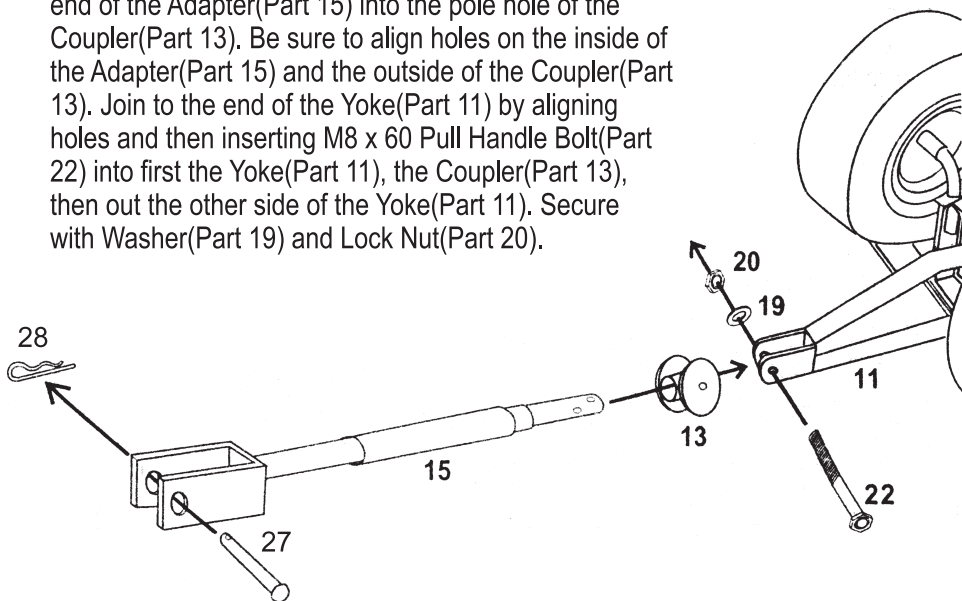

- A. CONTINUED...Connect to the end of your Tractor using Tractor Pull Bolt(Part 27), Secure on the other side with Small Quick Release Pin(Part 28).
- B. Pull Handle - Attach the Tractor Pull in the same manner as Step A. Instead of attaching to Tractor, use Tractor Pull Bolt(Part 27) and Small Quick Release Pin(Part 28) to attach Pull Handle. Insert The "U" shaped end of the Tractor Pull Adapter into the end of the Pull Handle. Align holes and insert Tractor Pull Bolt. Secure on the other side using Small Quick Release Pin(Part 28).

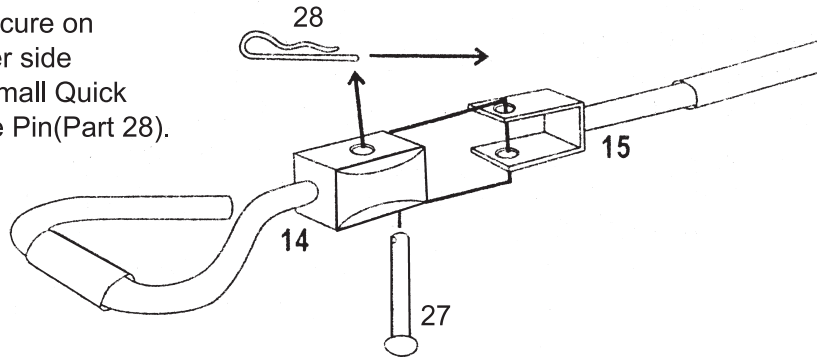

## FRAME ASSEMBLY:

Parts needed:

- #2 Side Panel
  - #3 Front Panel
  - #4 Back Panel
  - #16 Quick Release Pins
  - #18 Lock Handles  
-attached to  
Front and Back  
Panels
  - #19 Washers  
-attached to Front  
and Back Panels
  - #20 Lock Nuts  
-attached to Front  
and Back Panels
- Bed Assembly

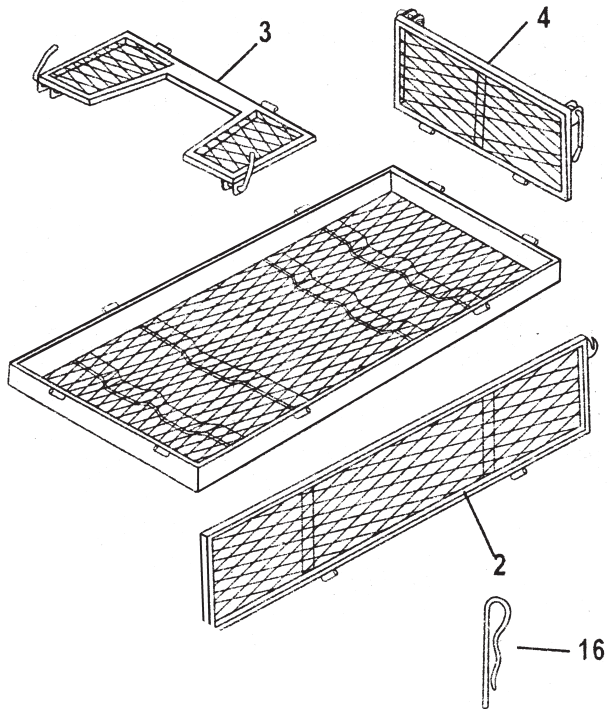

1. Join the Back Panel (Part 4) to the Bed (Part 1) by inserting two Quick Release Pins (Part 16) through the side loop located at the bottom of the Back Panel and the top edge of the Bed.

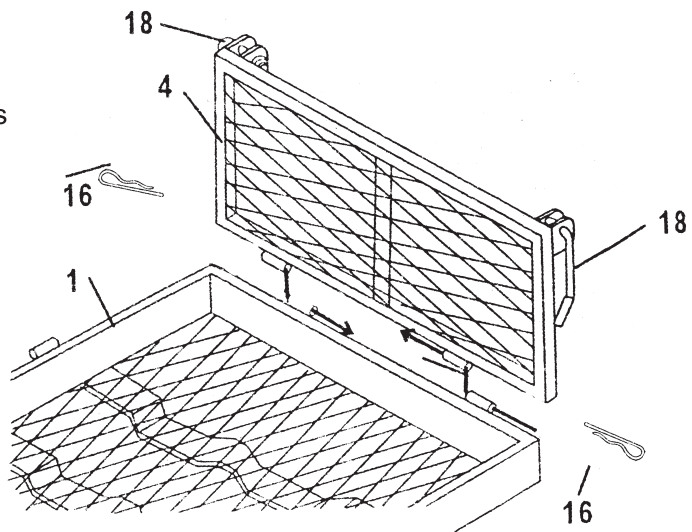

2. Join the side Panels (Part 2) to the Bed (Part 1) by inserting four more Quick Release Pins (Part 16) two per Side Panel into the loops at the bottom of the Side Panels and the top edge of the Bed.

3. Lift Lock Handles (Part 18) that have been pre-attached to the Front and Back Panels up and to secure the Back (Part 4) and the Side Panels (Part 2) together by firmly pressing the Lock Handle down and around the hook on the end of the Side Panel.

4. Repeat the process with the Front Panel (Part 3), Quick Release Pins (Part 16) and the two remaining Lock Handles (Part 18).

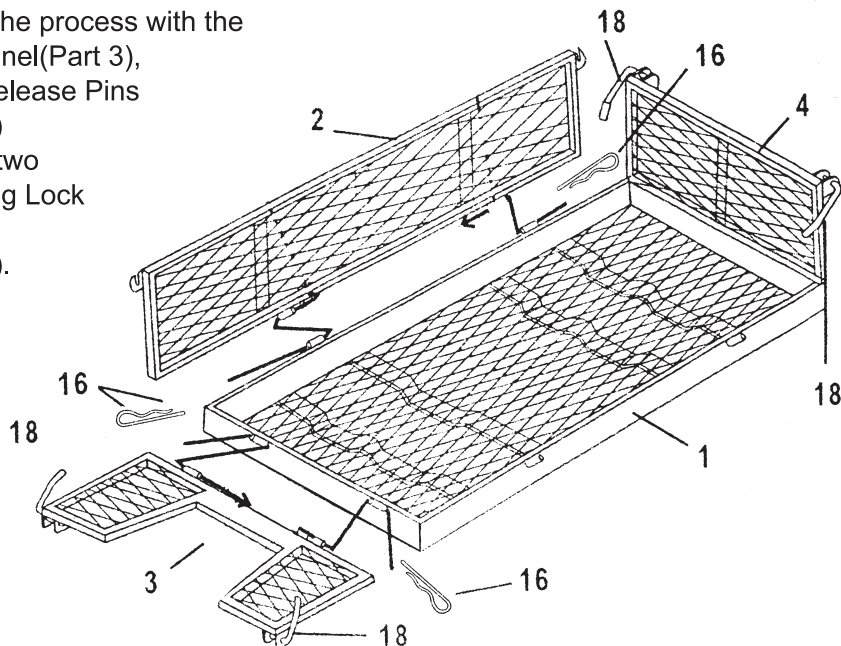

Centurion Garden & Outdoor Living  
 1191 Huntington Ave.  
 Wisconsin Rapids, WI, 54494  
 sales@centurionbrands.com  
 1-877-330-3366  
 www.centurionbrands.com